

Putzmeister

PUMI®

24-3.67 CS

Truck-mounted concrete pump with mixer

CS transfer tube system

MN 101270.001

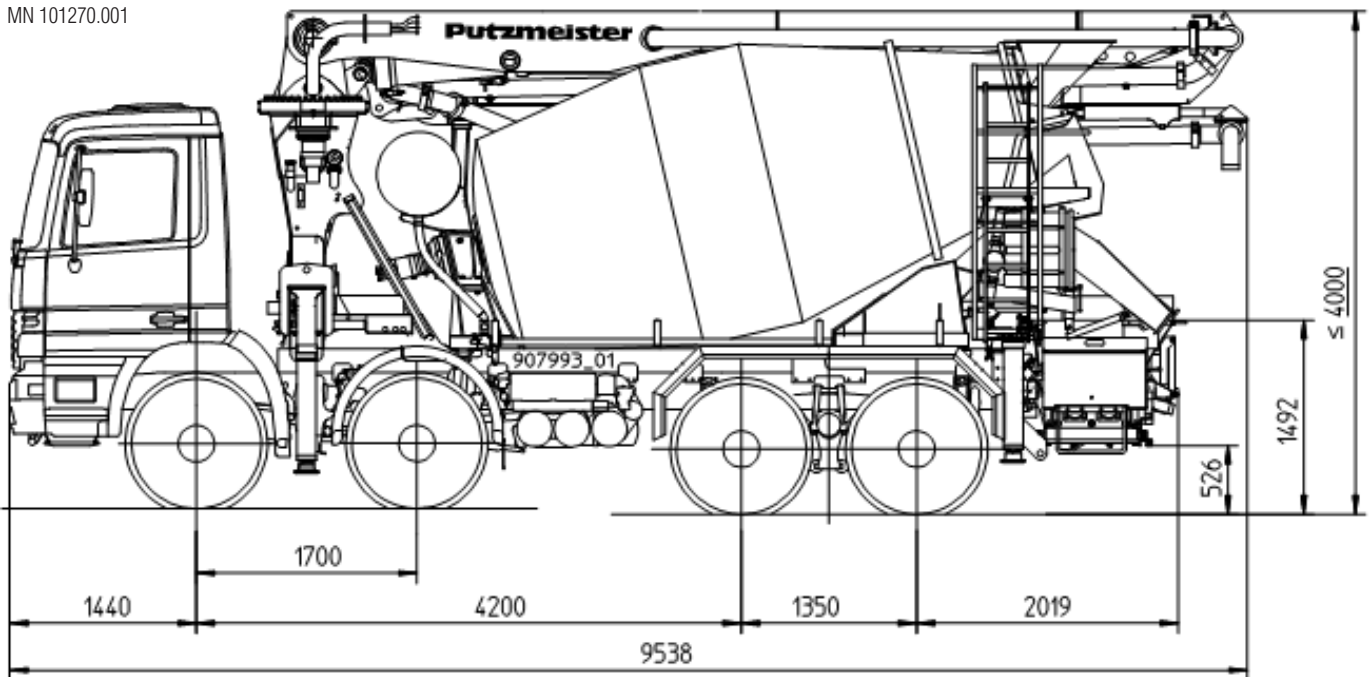

Note: Standard version. Dimensions and weights depend on boom, mixer and chassis.
Dimensions in mm, MB-Actros as example, total height depends on the chassis.

Technical data

Boom TMM 24-3		
Number of arms		3
Reach height	m	23.8
Horizontal reach	gross	m 20.0
	net	m 17.6
Reach depth max.	m	12.4
Unfolding height	m	6.9
End hose length	m	3
Folding system		Z fold (Z)
Delivery line		DN 125 – 5.5

Pump TMP 60 CS		
Output	m ³ /h	56
Delivery pressure	bar	57
Delivery cylinder	Ø mm	230
Stroke	mm	700

Maximum outputs of 56 m³/h and maximum concrete pressures of 57 bar may be achieved, depending on the equipment of the machine.

It is not possible to achieve maximum outputs and maximum concrete pressures simultaneously.

All data maximum theoretical.

Truck mixer 7 cbm		
Nominal capacity	m ³	7
Total capacity	m ³	11.5
Filling ratio	%	63
Power consumption	kW	52
Drum speed	rpm	1 - 14
Pressure tank for water	l	650

Reach information diagram, Support, Transfer tube

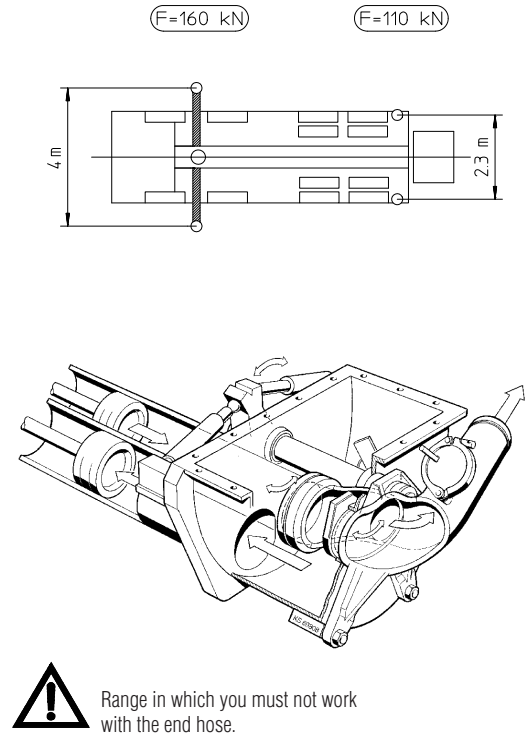
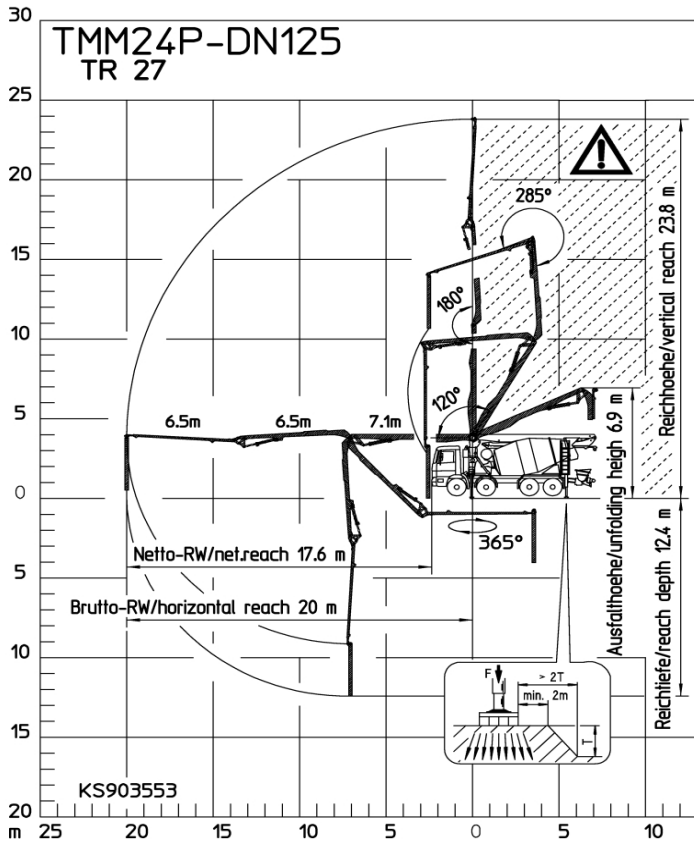

Delivery scope

Support	Electric control box with display and ergonomic diag. interface	Cleaning
Support legs rear T 0	EOC (Ergonic output control)	High pressure water pump 100bar with running dry connection
Support legs T 4	EPS (Ergonic pump system)	Cleaning hose with nozzle
Support plates 4x in 2 magazines	Information concrete stiffness on display	Bracket for hammer and cleaning brush
Illumination	Mixer control via chassis cabin with display	Cardan shaft maintenance free
Marker lamps lateral and rear side, EU	Delivery line	Safety
Working light for hopper illumination, mounted	Delivery line (1-layer) PM 40 (DN 125 5.5"), arm assembly	Agitator safety switch off
Extras	End hose 3.0 m DN 125 5.5"	Lateral underrun protection
Operating manuals 2 x (1 x paper, 1 x CD-ROM) spare part lists	Mixing drum	Underrun protection, rear side
Painting:	Truck mixer 7 cbm	Mudguard cpl. aluminium (bulb plate), rear axle
mixer MB 1227 chrome yellow	Water tank 650 l, pressure tank	Stowage compartment
pump MB 1227 chrome yellow	Water tap under water tank	Hose bracket for 6x DN 65, 5 m for 4 axle
arm assembly RAL 3020 signalred	Chute extension steel 1 x	Tool box plastic
Tool set incl. standard equipment	Ladder, telescopic	Hopper
Chassis horn operated in control box	EMC (Ergonic mixer control)	Concrete hopper with agitator
Compressed air connection	Mixer discharge automatically	Rubber collar on concrete hopper
Towing eye	Chute adjustment hydr. mechan.	Central lubrication hopper, electrically
Remote control	Second drip ring on mixer drum	Level indicator
Radio remote control fully prop.	Watertank filling from both sides	
Mixer-comfort-functions through display radio remote	Wear plate on discharge hopper	
Remote control CPC with 25 m cable	Wear plate on inlet hopper	
Control platform with display, rear side		

See quotation for exact serial delivery scope.
Comprehensive range of options available on request.